

Technical
Drawing

Desenho
Técnico

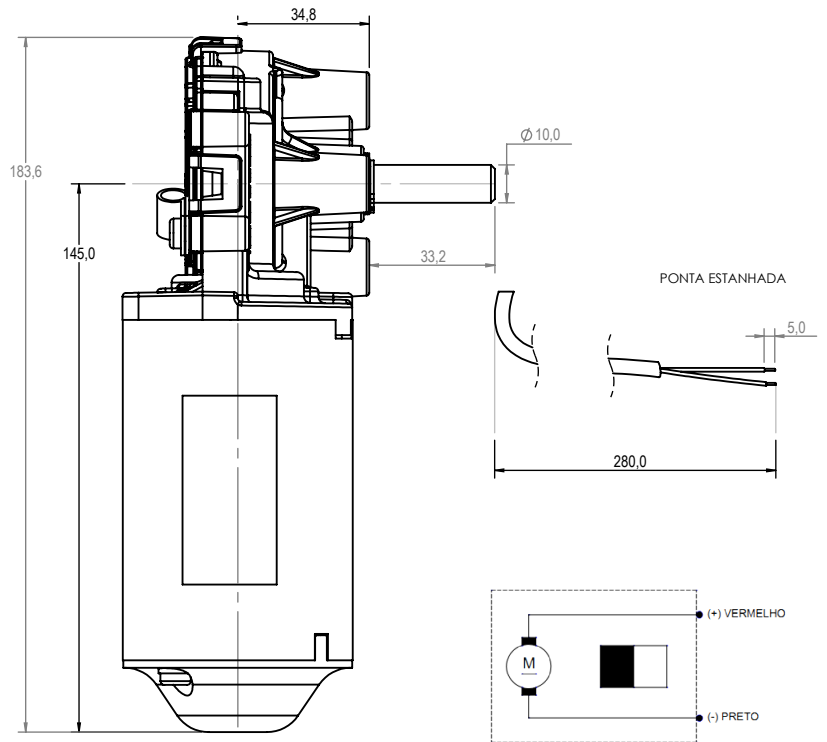
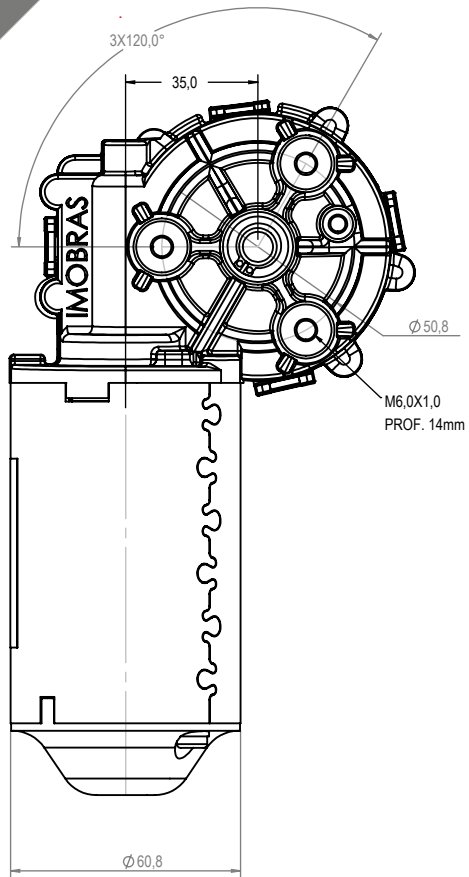

Technical
Specification

Especificação
Técnica

Imagem
Ilustrativa

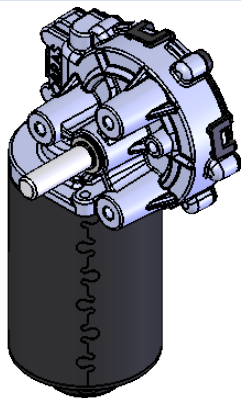

100401512

CARACTERÍSTICAS ELÉTRICAS	
U N (V)	13
P N (W)	40
n N (rpm)	63
I N (A)	7,5
I max (A)	45,5
M N (Nm)	6
M max (Nm)	30
I	63:1
Rotação	L / R
Peso (Kg)	1,500

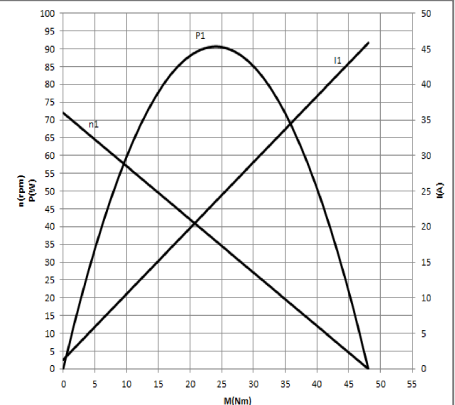

NOTAS:

Aplicação: Industrial

Application: Industrial

100401524

CARACTERÍSTICAS ELÉTRICAS	
U N (V)	27
P N (W)	45
n N (rpm)	72
I N (A)	4
I max (A)	29
M N (Nm)	6
M max (Nm)	30
I	63:1
Rotação	L / R
Peso (Kg)	1,500

